

Diagnosis Prediction of Lichen Planus, Leukoplakia and Oral Squamous Cell Carcinoma by using an Intelligent System Based on Artificial Neural Networks

Original Article

Rouhollah Maghsoudi¹, Abolfazl Bagheri²,
Mohammad Taghi Maghsoudi³

¹Instructor of Department of Computer, Islamic Azad University, Noor Branch, Noor, Iran.

²Assistant Professor, Oral and Maxillofacial Pathology, Dental School, Ardabil University of Medical Sciences, Ardabil, Iran.

³Student, Dental School, Guilan University of Medical Sciences, Guilan, Iran.

Received: May 16, 2013

Accepted: Jul 9, 2013

Corresponding Author:

Abolfazl Bagheri

Address: Ardabil University of Medical Sciences, Ardabil, Daneshgah st., Ardabil complex university, Ardabil, Iran

Telephone: +98-911-8333943

Fax: +98-451-5510054

E-mail: a.bagheri@arums.ac.ir

Abstract

Introduction: Diagnosis, prediction and control of oral lesions is usually done classically based on clinical signs and histopathologic features. Due to lack of timely diagnosis in all conventional methods or differential diagnosis, biopsy of patient is needed. Therefore, the patient might be irritated. So, an intelligent method for quick and accurate diagnosis would be crucial. Intelligent systems approach has been successful in prediction and diagnosis of factors. Intelligent instruments significantly contributed to the diagnosis of different disease, such as timely diagnosis of breast cancer, heart failures and so on. In this research, three of the most common and relatively dangerous oral diseases (lichen planus, leukoplakia and squamous cell carcinoma) have been studied using intelligent systems based on artificial neural networks (ANN).

Materials and Methods: In this study, the population of the study constituted one hundred and fifty, fifty patients are considered in each disease. The four features for learning intelligent systems given to it as an input.

Results: The output of this system includes charts and tables to determine the optimal prediction of machine. One of the figures represents the descent of error that is convergent to the global optimum. The extreme prediction of machine would be achievable with

the least amount of attention. So, the credibility and reliability will be boosted.

Conclusion: The purpose of this research is the application of artificial intelligence techniques in branch of dentistry to the aim of early diagnosis and treatment of oral diseases.

Key words: •Prediction, •Lichen Planus
•Leukoplakia •Carcinoma, Squamous Cell
•Artificial Neural Network

Introduction

The main concept of medical technology is to contribute to the specifications of diagnosis and diagnosis uncertain disease conditions. The number of quantitative models includes multi-layer perceptron neural networks (MLPNN), recursive neural networks (RNN), and support vector machines (SVM) which help the human decision against systems of medical diagnosis of disease.⁽¹⁾ Unfortunately, there is no theory about intelligent model selection guide based on the complexity of diagnosis. In most circumstances, the developers will simply use models that could result in satisfaction or as tools to examine the subset models with estimation of training sets. Neural networks were successfully used in different therapeutic applications.^(1,2) Many researchers have shown that the combination of predictions relating to different models in prediction will often be more accurate than the individual ones. General framework to predict, using a combination of two-level model is included.⁽³⁾ In the first level, different ways of learning for different learning models are applied to acquire different models of original data set. Prediction of these models of the first level and balance is aligned with purposeful group of information, that is to learn the second level of model. As the neural networks among the usual models can be used for patterns of classification, numerous studies

have been carried out which show the experimental and theoretical results on neural networks of prediction that have been found in this article. The accuracy of different methods for regular combination of neural networks is attributable to breast cancer which is listed in the database of relevant items.^(4,5) The obtained results of the combination of all neural networks are reported for liver disorders.⁽⁶⁾ Models of combined neural networks (CNN) were used to classify ultrasound signals.⁽⁷⁾ As the result of improving and expanding categories and accuracy of electrocardiogram signals, CNN model was completed.⁽⁷⁾

By analyzing recent developments, it is clear that there is a tendency towards the development of new methods for computer-assisted medical decision-making and evaluation of these methods in clinical practice. Artificial neural networks were used to identify different treatment and the results have been compared with the medical diagnosis and the existing classification methods.⁽⁶⁾ Many of them found that ANNs have flexibility in modeling and its prediction has logical accuracy that caused neural networks are tools to receive relatively optimal solutions of incomplete and limited data sets. So, it has been shown that neural networks can combine the data in different forms of a system, like the data which are achieved from clinical and experimental protocols of evaluation and features of signals and pictures. Thus the diagnosis system is completed.^(4,6)

The fuzzy systems are the other intelligent methods. The fuzzy logic is generalized from classical binary logic which moves slowly from true to false. The fuzzy systems are useful in development of system solutions which do things like modeling, prediction, pattern recognition and optimized decision-making, control and planning. The fuzzy systems are essential methods and tools for solving some specific

problems. In recent years, the fuzzy logic has been applied in any fields. The fuzzy model of Takagi-Sugeno has been much used in industrial applications. This fuzzy model is also used in the differential diagnosis of patients with lung, liver and stomach cancer from normal population based on samples of blood plasma.⁽⁸⁾

Machine learning is another theory that can be useful in developing an expert system. In the discussion of machine learning algorithms, a new classification algorithm as VF15 has been developed and used in the differential diagnosis of inflammatory squamous diseases. The records of patients with specific diseases have been studied. In the algorithm of VF15, each feature (effective factor in disease) participates equally in the voting process and the class that gains the most votes will be chosen as the predicted class.⁽⁹⁾

In this paper, diagnosis and prediction of Lichen Planus, Leukoplakia and Oral Squamous Cell Carcinoma diseases have been studied. Hereunder, three diseases will be explained.

Lichen Planus is a mucosal chronic inflammatory skin disease that mainly involves the mouth mucosa. This disease affects about half to two percent of the population, occurring mostly in women at an average age of forty or fifty.⁽¹⁰⁾ Clinically, the disease is usually described by white papules with a network of lines and sometimes are associated with the parts of erosive or atrophic.⁽¹¹⁾ Oral Lichen Planus may involve any part of the oral cavity but the buccal mucosa, tongue and gums are the most common sites.⁽¹²⁾ Although the cause of the disease is unknown, a cell-mediated immunological response to an antigenic change in skin or mucosa may be the one. The disease can also be caused by medications, a condition known as lichenoid reaction.

Leukoplakia is the most common oral

mucosal precancerous lesion that the World Health Organization describe it as a lesion with a pack or white plaques on oral mucosa which are not removed by cutting and scraping and it cannot be classified clinically or microscopically as another disease.⁽¹³⁾ Leukoplakia is divided into several different types: thin or mild, thick or homogenized and nodular or granular. Men constitute 70% of the population with the average age of sixty.⁽¹⁴⁾ The lesion involves mostly vermilion of lip, buccal mucosa and gums. Various stages of treatment have been reported for oral leukoplakia.

Oral squamous cell carcinoma involves more than 90% of malignancies of mouth and oropharynx. Squamous cell carcinoma is one of the ten most common cancers in the world which affects aged men⁽¹⁵⁾ The life expectancy is less than 50% for five years that shows a prognosis less than breast cancer and melanomas. The disease mostly affects the tongue, palate and floor of mouth. Despite advances in radiotherapy, chemotherapy and development of surgical techniques, oral squamous cell carcinoma is still cause of many deaths. It is clear that carcinomas occur from several points of precancerous changes which are involved in carcinogenic process. Oral Lichen Planus and Oral Leukoplakia are two types of common precancerous diseases of the oral squamous cell carcinoma.⁽¹⁶⁾

Materials and Methods

Artificial Neural Networks

Neural networks emerged in two periods of development in the 60s and in the middle of 80s inspired by biological behavior of the human brain to solve problems by imitating human performance. The structure of artificial neural network is inspired by nerve cells in the body. Neural networks are a class of general nonlinear non-parametric models and have a block with a mathematical model of one neuron, which is

the main components in the process of communication and each of them act independently and in parallel. Each neuron consists of a cell body, axon and dendrite. The three parts form a nerve cell that has the ability to send and receive information.^(16,17)

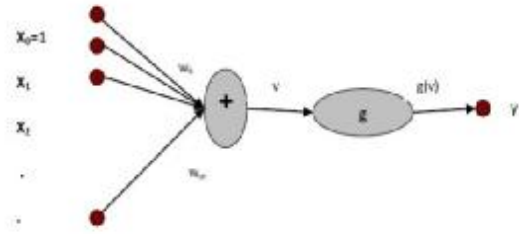

Figure 1: a simple structure of an artificial neural node, x_0, x_1, \dots , are inputs, $w_0 \dots w_m$ are weights of each input, plus symbol is summation of inputs multiply weights, and g is a activation or transfer function that converts v (initial output) to y (final output).

It can be said that neural networks are robust against sudden changes and have the ability to train and generalize in environments that are rich in terms of data and are identified as a powerful tool for prediction and classification of various problems in artificial intelligence. Neural networks obtain intelligence from training process and the intelligence gives them the ability to automatic matching and cooperation to perform specific tasks. In the predicted functions, neural networks have nonlinear models which train in a way that provide data of time series with future quantities and since they obtain valuable information from a mass of the last data, are useful for practical applications. Neural networks have wide uses in areas such as computer sciences, medicine, economy, pattern recognition, prediction, classification, and financial phenomena. In terms of prediction, neural networks are useful in predicting

stock market, bankruptcy, commodity rates, electricity consumption, and weather forecast. The motivation of modeling a biological neural network led to designing an artificial neural one. The simple structure of an artificial neural network and complete structure of a multi-layer neural network are shown in figures 1 and 2 respectively.

Input data enters the network as parameter p , then multiplied by a set of synaptic weights and aggregated with the bias of b , the amounts (weights and bias) are random. After this, the calculated value is delivered to transfer function of f and the output value is shown with a . The output of each layer will be in fact as input to the next layer. NeuralK networks consist of several active layers and there are various neurons in each layer. Finally, the ultimate output is compared to a desired value and the calculated error will be spread through the variable values of α and W in network (perceptron neural network). The training process continues until error criterion reaches close to zero. After network training was completed, it can be used as an operational and practical model.^(16,17,18)

There are various models and architectures of artificial neural networks. Multi-layer perceptron architecture with back propagation learning algorithm, which is the most famous models, has been used to identify the above mentioned diseases.

Results

We collected data, some of them of foreign journals, on 150 patients. The 150 patients were divided into three groups of fifty, each group to one disease. The four features which are common in these diseases intended for the diseases (white lesion, oral involvement, age, gender), are selected and encoded to the range of [0,1] and then we entered the four common into the system in the forms of parameters p_1 to p_4 and with specific codes. Then, we entered into the

system 120 patients for training and 30 remaining patients for testing and validation of intelligent system. You can see a sample

of quad features related to diseases, which are classified in table 1.

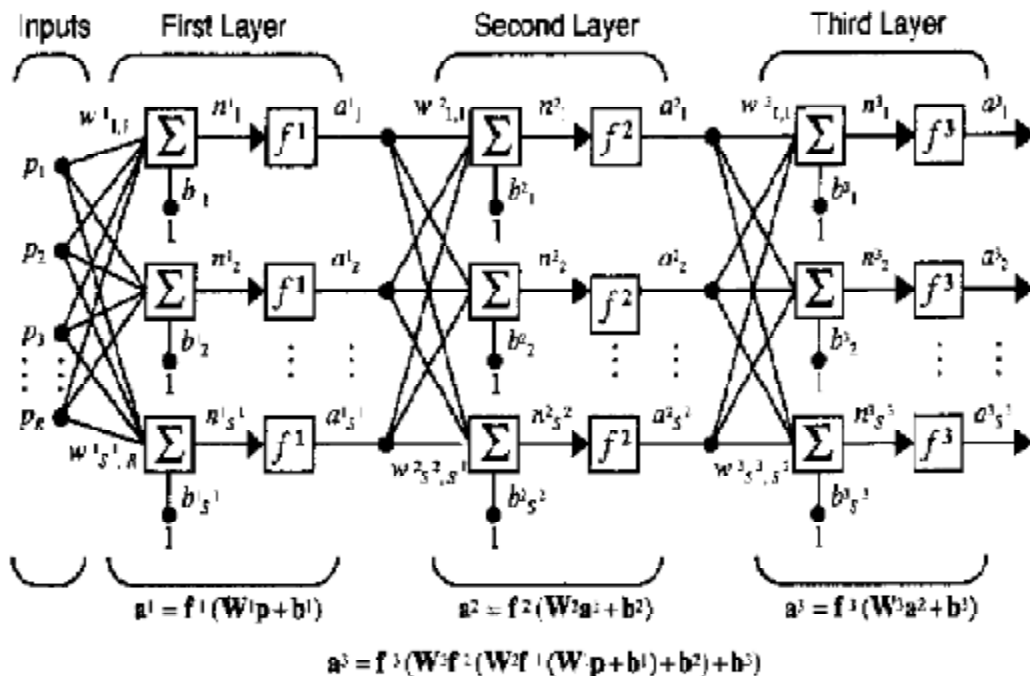

Figure 2: Structure of a multilayer neural network which is identically same as used in [18]

Table 1: Examples of the common features of three diseases

Kind of Lesion	Location of Lesion	Age	Sexuality	Disease	Row
White Papules & Plaques	Gum & Cheek	12	Male	Lichen Planus	1[12]
White Patches of Exophytic	Palate & Buccal Mucosa	47	Female	Leukoplakia	2
Yellow & White Papules	Palate	66	Male	Oral Squamous Cell Carcinoma	3
Popular Lesions	Gums & Tongue	50	Male	Lichen Planus	4
White Lesion with Erythematosis	Lip-Vermilion	62	Female	Leukoplakia	5
White Lesion with Irregular Shape And Scarred	Vestibule	60	Female	Oral Squamous Cell Carcinoma	6
Bilateral Lesion with Wickham’S Lines	Cheek	24	Male	Lichen Planus	7
Masses of White	Buccal Mucosa	51	Female	Leukoplakia	8[13]
Sunken Central Area with Smooth Surface	Tongue	44	Male	Oral Squamous Cell Carcinoma	9

At first, the graph of error rate was recorded after being repeated many times. It can be observed in figure 3. The horizontal axis shows the iterations and the vertical axis shows the mean of the squared error. As

it can be observed in the graph below, the error rate with successive repeats has declined and in the hundredth repetition, was below 0.02 and this indicates that the training of system was successful.

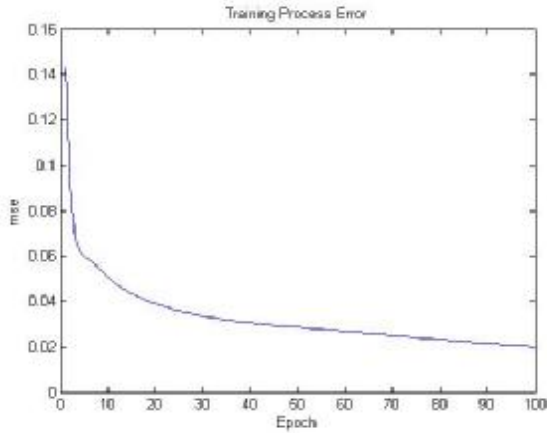

Figure 3: Diagram of the system error rate

Once 120 patients were entered into the system for training, a diagram was recorded which consisted of two red and blue output. The blue output is related to desired and actual values and the red related to the diagnostic value of our intelligent system. The parts of the diagram, in which red output does not match on the blue output with a little distance between them, indicate the training error of 0.0199 of our intelligent system. You can see the diagram related to the training error of the system in figure 4.

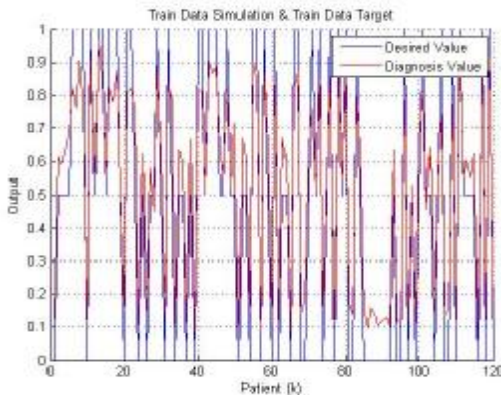

Figure 4: The Diagram of the process of system training

Thirty patients were included in the system for testing and validation. A diagram was obtained similar to the above graph, but the difference is that the error of testing system was 0.0196 and this negligible error shows the extraordinary ability of intelligent

system in diagnosis and prediction of diseases. You can see the diagram related to the error of testing system in figure 5.

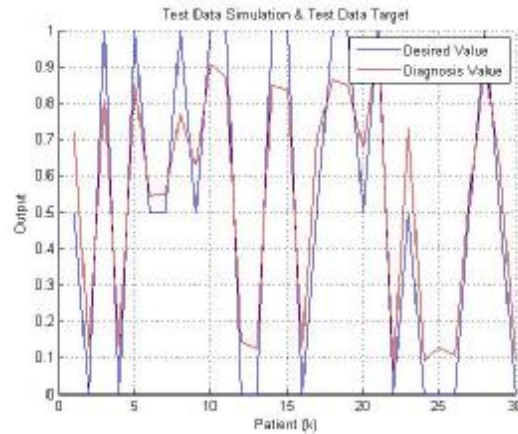

Figure 5: Diagram of the error of system testing

Discussion

In the analysis of findings and considering the four common features of diseases, it can be said that white lesions, which involve various parts of the oral cavity, have wide range. By encoding all white lesions, we can help the expert system in diagnosis of the type of the white lesion. If white lesion is radial white stripes, the diagnosis will be closer to Lichen Planus. If it is the white packs, the diagnosis will be closer to leukoplakia and if the white lesion is in the form of erythematous areas with central scars, the diagnosis will be closer to Oral Squamous Cell Carcinoma and so, with classification of white lesions and encoding them, we can help an intelligent expert system in diagnosis.

The oral involvement may be various, for example, in patients with Lichen Planus, the cheek may not be exclusively involved and other parts of oral cavity may also be affected due to disease progression such as gums, buccal mucosa and so on. By giving the codes closer to diagnosis, we can help an expert system in diagnosis and prediction. For instance, in the simulations we did, if one of the four common features of a disease

is given a code close to 1 (for example; 0.80, 0.85, 0.90), it shows that, the feature will be very close to the intended disease and with the assessment of the other three features related to the disease, the expert system will diagnose it.

Age was one of the four common examined features, too. For example, leukoplakia and oral squamous cell carcinoma mostly involve the people over the age of 55 to 60.⁽¹⁹⁾ And, Lichen Planus also occurs in people above 40 to 45.⁽¹⁰⁾ However, it is a general principle and the three diseases may occur in people of different age.

Gender of the patient is also one of the four common features. For example, leukoplakia and oral squamous cell carcinoma occur in males and Lichen planus mostly occurs in females. We can encode this feature like other features and enter as

one of input parameters into intelligent system to act more strongly in diagnoses. So, it can be said that the four common features can be good standards of training system and finally of diagnosis by intelligent system.

Conclusion

The purpose of this study is the use of computer artificial intelligence techniques in diagnosis and prediction of oral and dental diseases quickly and accurately. We should typically move toward modern dentistry, because modern science has led to the intelligent techniques and applications in today's global society. The results of our simulation, which had been recorded as different diagrams, indicate that diagnostic systems, based on artificial neural networks, give a powerful strategy in diagnosis and prediction of oral and dental diseases.

References

1. Übeuli E D. Multiclass support vector machines for diagnosis of erythematous-squamous diseases. *Expert Systems with Applications* 2008; 35:1733-1740.
2. Miller A S, Blott B H, Hames T K. Review of neural network applications in medical imaging and signal processing. *Med Biol Eng Comput* 1992; 30, 449-464.
3. Wolpert D H. (1992). Stacked generalization. *Neural Networks* 1992; 5: 241-259.
4. Übeuli E D. Combined neural networks for diagnosis of erythematous-squamous diseases. *Expert Systems with Applications* 2009; 36: 5107-5112.
5. Taniguchi M, Tresp V. Combining regularized neural networks. In: Gerstner W, Germond A, Hasler M, Nicoud J. *Proceedings of the ICANN'97, Lecture Notes in Computer Science 1327*. Berlin: Springer; 1997. pp. 349-354.
6. Hayashi Y, Setiono R. Combining neural network predictions for medical diagnosis. *Comput Biol Med* 2002; 32(4), 237-246.
7. Güler I, Übeyli E D. ECG beat classifier designed by combined neural network model. *Pattern Recognition* 2005; 38(2): 199-208.
8. Zhuoyong Zh, Hualan Zh, Sidong L, et al. An application of Takagi-Sugeno fuzzy system to the classification of cancer patients based on elemental contents in serum samples. *Chemometrics and Intelligent Laboratory Systems* 2006; 82: 294-299.
9. Altay Gu H, Demiroz G, Ilter N. Learning differential diagnosis of erythematous-squamous diseases using voting feature intervals. *Artificial Intelligence in Medicine* 1998; 13: 147-165.
10. Lo Muzio L, Mignogna MD, Favia G, et al. Review The possible association between oral lichen planus and oral squamous cell carcinoma: a clinical evaluation on 14 cases and a review of the literature. *Oral oncology* 1998; 34: 239-246.
11. Perdigão PF, Guimarães AL, Victoria JM, et al. Serotonin transporter gene polymorphism (5-HTTLPR) in patients with oral lichen planus. *Arch Oral Biol* 2007; 52(9): 889-93.
12. Wilson E. On lichen planus. *Journal of Cutaneous Medical Diseases of the Skin* 1869; 3:117-132.

13. Ishii J, Fujita K, Komori T. Laser surgery as a treatment for oral leukoplakia. *Oral Oncology* 2003; 39: 759-69 .
14. Natarajan E, Woo SB. Benign alveolar ridge keratosis (oral lichen simplex chronicus): A distinct clinicopathologic entity. *J Am Acad Dermatol.* 2008; 58(1): 151-7.
15. D'Silva NJ, Ward BB. Ward. Tissue Biomarkers for Diagnosis & Management of Oral Squamous Cell Carcinoma. *Alpha Omegan* 2007; 100(4): 182-190.
16. Yan SK, Wei BJ, Lin ZY, et al. A metabonomic approach to the diagnosis of oral squamous cell carcinoma, oral lichen planus and oral leukoplakia, *Oral Oncology* 2008; 44: 477-483.
17. Giovanni H. soft computing Techniques Applied to short – term Traffic Flow Forecasting. *Systems Analysis Modeling Simulation.* 2003; 43 (2): 165-173.
18. Wu H, cong Y, Jiang G Y, et al. study on short - term prediction Methods of Traffic Flow on Expressway based on Artificial Neural Network, *Proc. Signal and Image Processing (SIP 2005)*; Honolulu, Hawaii, USA, 2005.
19. Hagan M T, B. Demuth Howard, Beale M. *Neural Network Design.* 1nd ed. United States, PWS Publishing Company; 1996; pp. 40-50.
20. Natarajan E, Woo SB. Benign alveolar ridge keratosis (oral lichen simplex chronicus): A distinct clinicopathologic entity. *J Am Acad Dermatol.* 2008 Jan; 58(1): 151-7.
21. Hayashi Y, Setiono R. Combining neural network predictions for medical diagnosis. *Comput Biol Med* 2002; 32(4), 237–246.
22. Güler I, Übeyli E D. ECG beat classifier designed by combined neural network model. *Pattern Recognition* 2005; 38(2): 199-208.
23. Taniguchi M, Tresp V. Combining regularized neural networks. In: Gerstner W, Germond A, Hasler M, Nicoud J. *Proceedings of the ICANN'97, Lecture Notes in Computer Science 1327.* Berlin: Springer; 1997. pp. 349-354.